

DLA-NP5

Native 4K Home Theater Projector

4K THAT RIVAL'S REALITY



The DLA-NP5 delivers all the essentials: 1,900 lumen brightness, Native 4K resolution and 48Gbps HDMI inputs which is the latest connectivity standard. It offers impressive HDR even with larger screen sizes. A 65 mm diameter all glass lens provides a wide zoom and shift range for installation flexibility. Add D-ILA imaging chips, HDR10+ and Frame Adapt HDR for an impressive home theater experience.

KEY FEATURES

- 1,900 Lumen Light Engine with High Power Lamp (PKL2618U)
- Two 48Gbps HDMI/HDCP 2.3 inputs (4K/120P compatible)
- HDR10+
- 0.69 inch Native 4K D-ILA Devices (x3)
- 65 mm all-glass lens with 2X Zoom and 80% vertical/ 34% horizontal shift
- 40,000:1 Native Contrast, 400,000:1 Dynamic Contrast
- Frame Adapt HDR Dynamic Tone Mapping w/ Theater Optimizer
- Installation Mode with 10 memories, Anamorphic Scaling
- ISF (Imaging Science Foundation) Licensed plus JVC Auto Calibration
- Clear Motion Drive w/Motion Enhance
- Multiple Pixel Control (MPC) — MPC works with 4K60P (4:4:4) signals
- Low Latency Mode improves picture, speeds operation, and reduces gaming/PC frame delays
- Control: Control4 SDDP / LAN / RS-232C / IR / 12V Screen Trigger Output / 3D Sync Output
- 3 Year Warranty with First Year Advanced Replacement

Dual 48Gbps HDMI w/ HDCP 2.3 Inputs

The DLA-NP5 offers dual 48Gbps HDMI inputs with HDCP 2.3. 4K/120P input is supported for the newest generation video content, including the latest gaming platforms.



From Blu-ray and gaming consoles to 4K streaming services, native 4K content can be enjoyed to its fullest on JVC D-ILA projectors without conducting any upscaling process.

Frame Adapt HDR w/Theater Optimizer

The DLA-NP5 is compatible with HDR10 content such as UHD Blu-ray and streaming. Color grading of HDR content can vary dramatically. Frame Adapt HDR dynamically tone maps all HDR10 content for optimized brightness, color and detail on a frame by frame or scene by scene basis. With Theater Optimizer, JVC has created the world's first projector that automatically fine tunes HDR based on installation characteristics, projector settings and even lamp age.



JVC projectors featuring Frame Adapt HDR and Theater Optimizer can express HDR content at optimum brightness and darkness in each frame as the creator intended.

An All Glass Lens Offers Premium Picture with Installation Flexibility

The DLA-NP5 is equipped with a 65mm diameter, high resolution, 17 element, 15 group all glass lens to deliver 4K resolution on the screen. For excellent installation flexibility, a wide shift range of +/-80% vertical, +/-34% horizontal is offered.



High-quality 65 mm diameter, 17-element, 15-group all glass lens



JVC is proud to add HDR10+ support, which offers dynamic tone mapping for 4K HDR Blu-ray & streaming content that is true to the director's intent.

Installation Mode

The DLA-NP5 offers Installation Mode that saves and recalls up to 10 different combinations of lens settings for different aspect ratios, lens presets, convergence and screen masking positions.

4K Anamorphic Scaling

This projector is compatible with commercially available anamorphic lenses and ultra-wide format screens for an immersive movie theater experience. It also features a scaling mode that is optimized for the full native 4096 x 2160 (17 x 9) resolution of the D-ILA device.

Superior Color Performance and Contrast

JVC's latest lineup of projectors incorporate many functions that enhance the color, brightness and contrast performance.

- **Auto Calibration** optimizes image quality under various installation conditions and also compensates for the changing color balance in long-term projector usage.
- **Vibrant and dynamic imagery** comes from the ultra-high-pressure lamp, a highly efficient optical engine and the narrow pixel gap of the D-ILA device.

Optional Equipment



Specifications

DLA-NP5		
Device	0.69 in D-ILA Device (4096 x 2160) x3	
Display Resolution	4096 x 2160	
Lens	2x Motorized Zoom & Focus, All-glass Lens 65 mm diameter	
Lens Shift	Vertical/Horizontal (motorized, in 16:9 aspect ratio) ±80% / ±34%	
Projection Display Size	60 inch - 200 inch diagonal	
Light Source	NSH 265 W	
Brightness	1,900 lm	
Contrast Ratio	Native: 40,000:1 Dynamic: 400,000:1	
Input Terminals	HDMI	2 (48Gbps, HDCP2.3, no support for CEC)
	Trigger	1 (Mini Jack, DC12V/100mA)
Output Terminals	3D Synchro	1 (Mini-Din 3pin)
	RS-232C	1 (Dsub 9pin)
Control Terminals	LAN	1 (RJ-45)
Service Terminals	SERVICE	1 (USB Type A, for firmware update)
Power Consumption	Projector in use	420 W
	Standby	Eco-mode: 0.3 W
	Networked standby	1.5 W (LAN)
Fan Noise		24 dB (In Low Mode)
Power Requirement		AC100-240 V, 50/60 Hz
Dimensions	(WxHxD-inches)	19 3/4 x 9 3/16 x 19 1/2
Weight (net)	(lbs)	41.9

External Dimensions (unit: inches/mm)

DLA-NP5

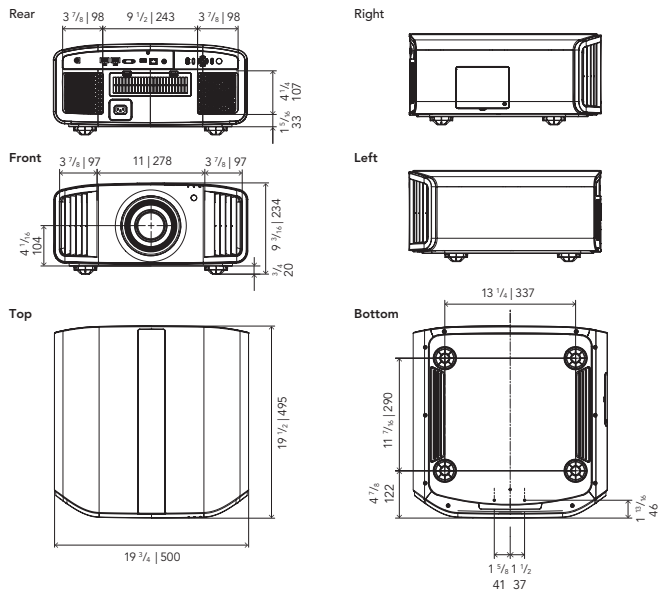

- Design and specifications are subject to change without notice.
- All pictures on this brochure are simulated.
- The DLA-NP5 is equipped with an ultra-high pressure mercury lamp, which may break, emitting a loud noise, when it is subjected to shock or after it has been used for some length of time.
- Please note that, depending on how the projector is used, there can be considerable difference regarding how many hours the light source will operate before requiring replacement.
- An additional payment is required for installation of the projector or a new light source, if necessary.
- HDMI, the HDMI logo and High-Definition Multimedia Interface are registered trademarks of HDMI Licensing LLC.
- All other brand or product names may be trademarks and/or registered trademarks of their respective owners.

Copyright © 2021, JVCKENWOOD Corporation. All Rights Reserved.

JVCKENWOOD

jvc.com

Printed in the U.S.A.

"JVC" is the trademark or registered trademark of JVCKENWOOD Corporation.