

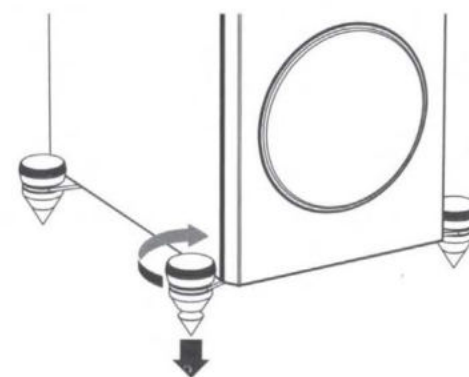

MOTION XT[®]
by **MARTIN LOGAN[®]**

quick start guide
F200 / F100 / F20 / F10

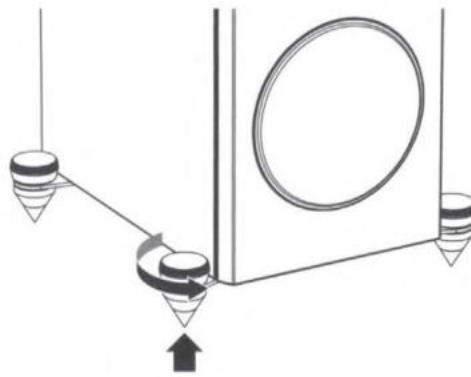

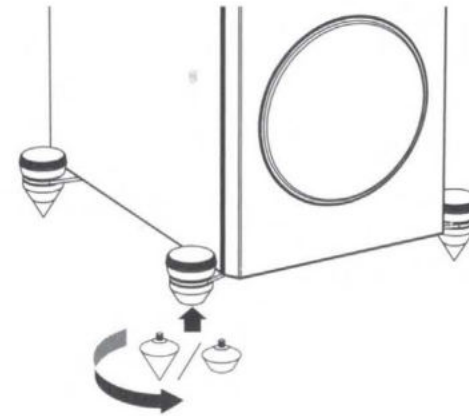
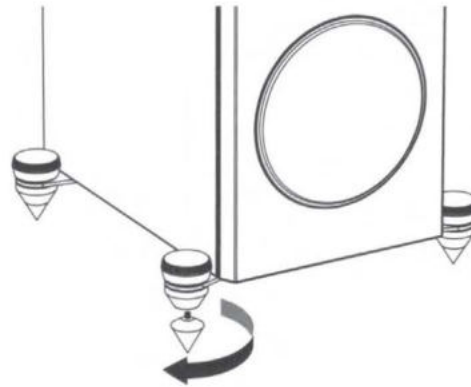
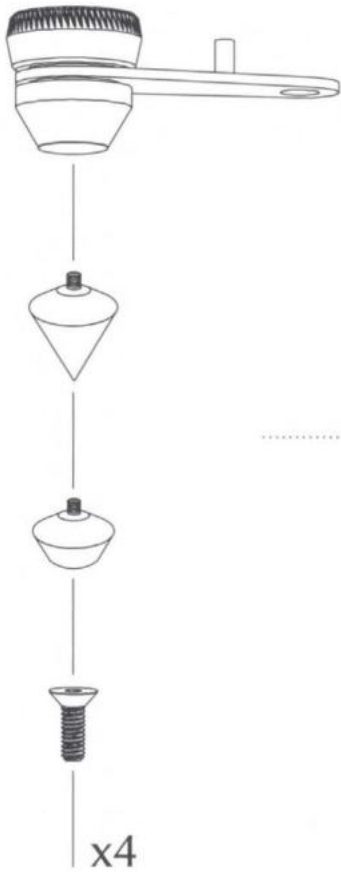
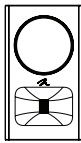
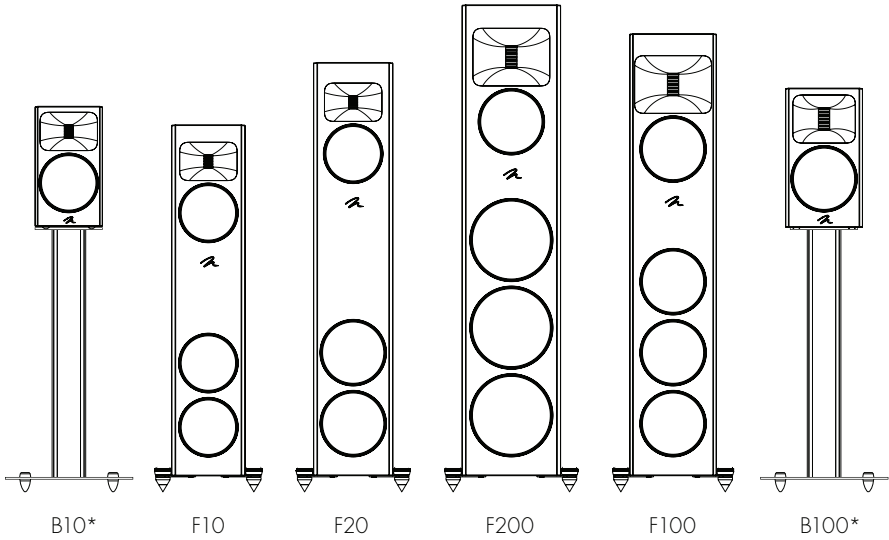

MP10

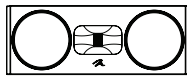

C10

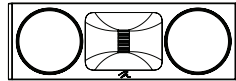

C100



WARNING!

- Refer servicing to a qualified technician.
- To prevent fire or shock hazard, do not expose this module to moisture.
- Turn amplifier off should any abnormal conditions occur.
- Do not drive speaker beyond its rated power.



The lightning bolt flash with arrowhead symbol, within an equilateral triangle, is intended to alert the user to the presence of potentially "dangerous voltage" within the product's enclosure that may be sufficient to constitute a risk of electric shock.



The exclamation point within an equilateral triangle is intended to alert the user to the presence of important operating and maintenance (servicing) instructions in the literature accompanying the appliance.



In accordance with the European Union WEEE (Waste Electrical and Electronic Equipment) directive effective August 13, 2005, we would like to notify you that this product may contain regulated materials which upon disposal, according to the WEEE directive, require special reuse and recycling processing. For this reason Martin Logan has arranged with our distributors in European Union member nations to collect and recycle this product at no cost to you.

To find your local distributor please contact the dealer from whom you purchased this product, email info@martinlogan.com or visit the distributor locator at www.martinlogan.com.

Please note, only this product itself falls under the WEEE directive. When disposing of packaging and other related shipping materials we encourage you to recycle these items through the normal channels.



**Motion STAND25 sold separately.*

Connection	6
Single Wire Connection (C10/B10/MP10)	6
Single Wire Connection (F200/F100/C100/B100/F20/F10) . . .	6
Jumper Clips (F200/F100/C100/B100/F20/F10) . . .	6
Bi-Wire Connection (F200/F100/C100/B100/F20/F10) . . .	6
Passive Bi-Amplification (F200/F100/C100/B100/F20/F10) . . .	7
Active Bi-Amplification.	7
Placement	
(F200/F100/B100/F20/F10/B10)	8
Frequently Asked Questions	9
Troubleshooting	10
Contacting Customer Service	10
General Information	11
Warranty Information	11
Serial Number.	11
Service	11
Specifications	12
Dimensional Drawings	18

Serial Number: _____

Record your serial number here for easy reference. You will need this information when filling out your warranty registration. The serial number is located near the binding posts and on the product carton.

Motion XT F200/F100
Motion F20/F10

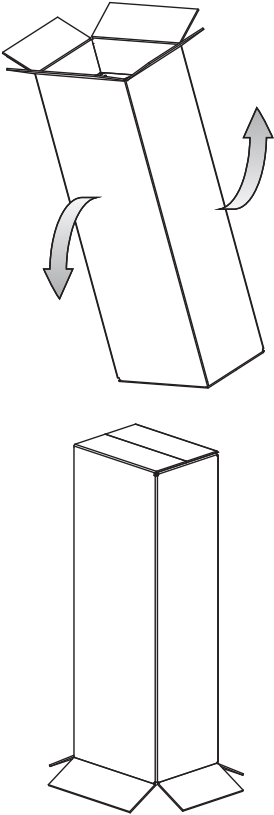
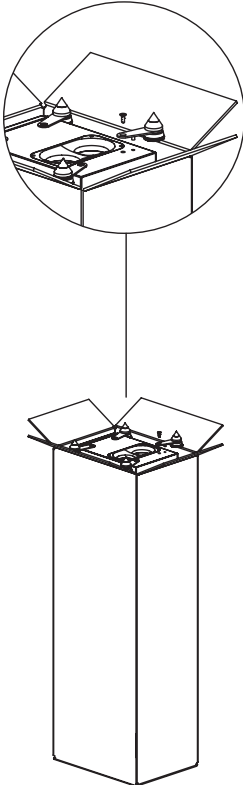
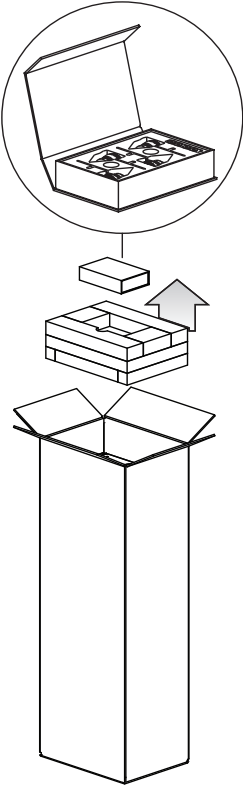

Motion XT B100
Motion B10

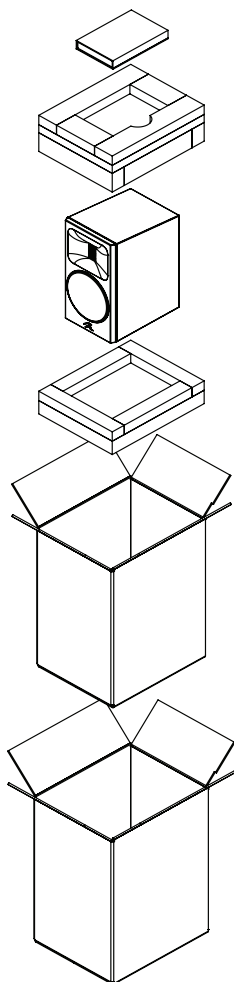

Motion XT C100
Motion C10

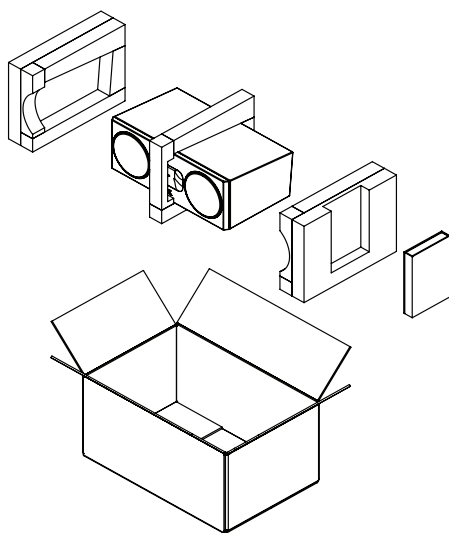

Motion MP10

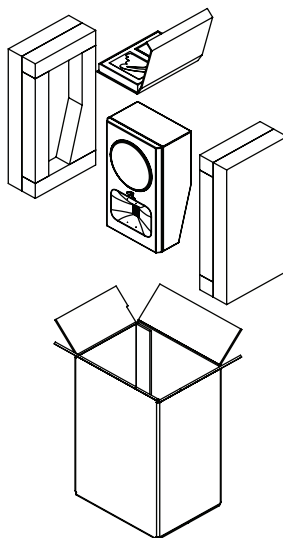

CONNECTION

WARNING! Turn your amplifier off before making or breaking any signal connections!



SINGLE WIRE CONNECTION (C10/B10/MP10)

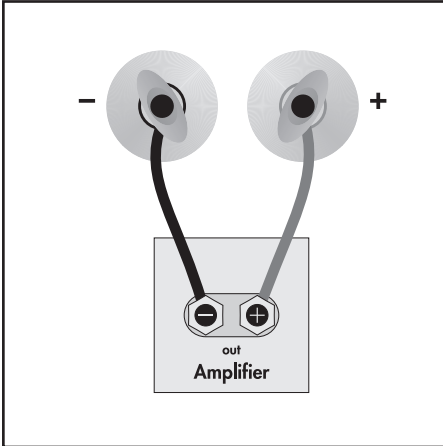

SINGLE WIRE CONNECTION (F200/F100/C100/B100/F20/F10)

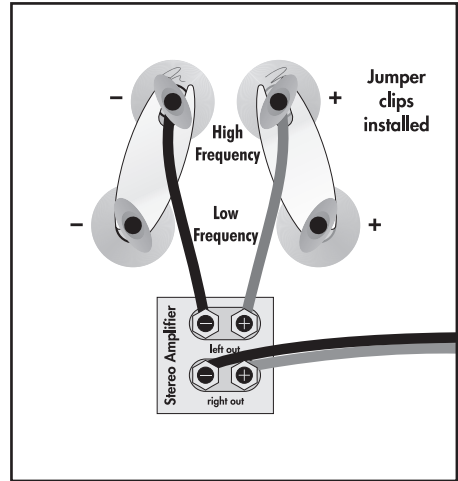

BI-WIRE CONNECTION (F200/F100/C100/B100/F20/F10)

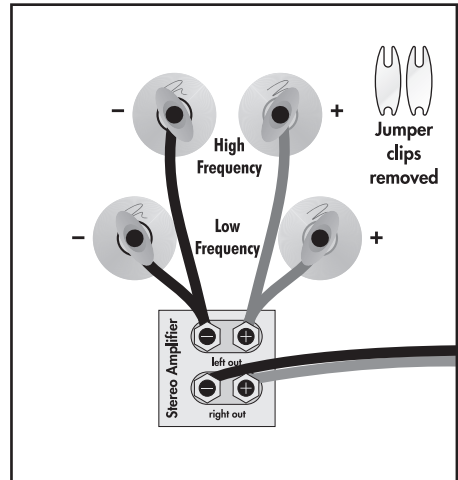

JUMPER CLIPS (F200/F100/C100/B100/F20/F10)

WARNING! Only after jumper clips are removed may you connect individual runs of speaker cable from your amplifiers to the high-frequency and low-frequency signal input binding posts. Damage will occur to your amplifiers if the jumper clips are not removed.



In some countries federal law prohibits MartinLogan from supplying jumper clips. If none are found installed under your speakers binding posts, please refer to 'Bi-Wire Connection' for connection instructions.

**PASSIVE BI-AMPLIFICATION
(F200/F100/C100/B100/F20/F10)**

Horizontal Passive Bi-Amplification

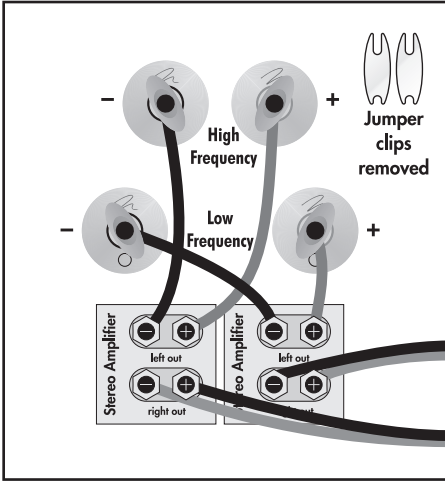

Vertical Passive Bi-Amplification

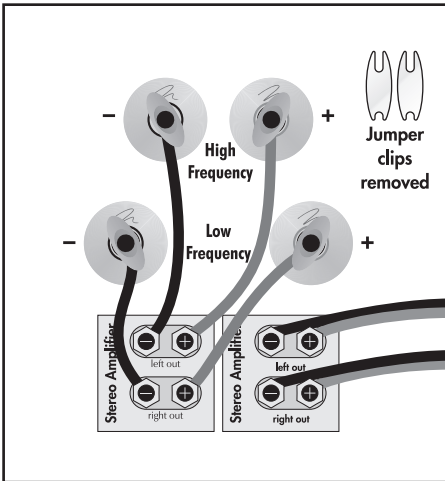

ACTIVE BI-AMPLIFICATION

We do not recommend active bi-amplification. The internal crossover can not be bypassed. This connection method seriously degrades performance.

PLACEMENT

BREAK IN



72 hrs

Allow approximately 72 hours of break-in at 90 dB (moderate listening levels) before any critical listening.

PLACEMENT

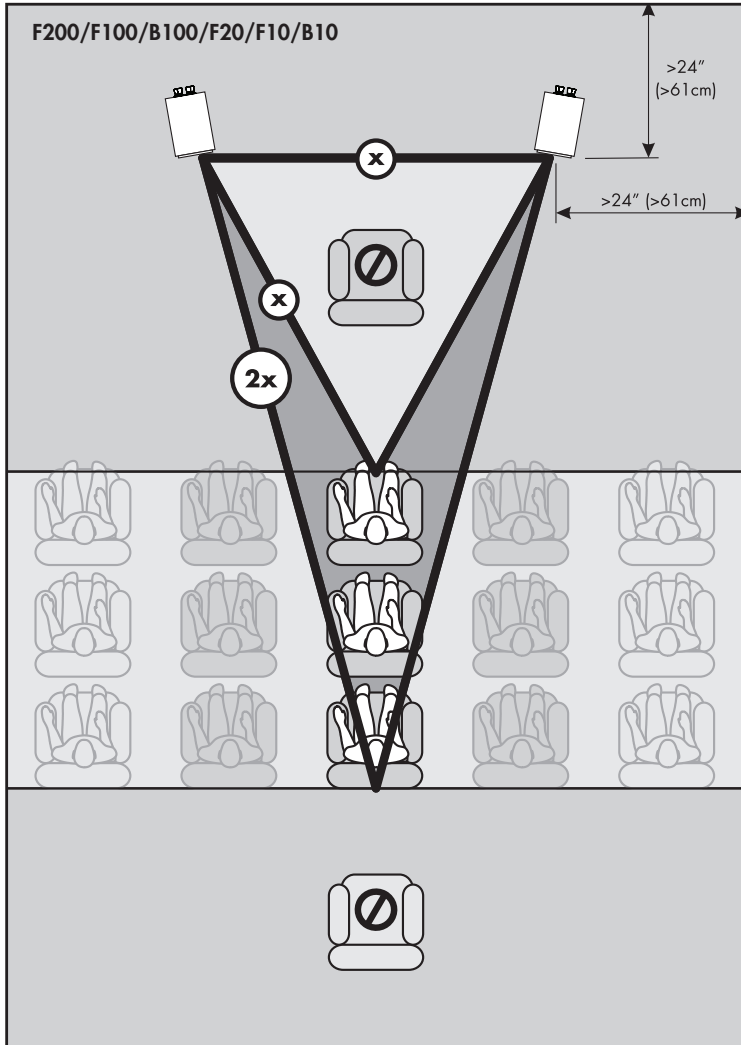

FREQUENTLY ASKED QUESTIONS

How do I clean my speakers?

Use a dust free cloth (such as a micro fiber cloth) or a soft brush to remove dust from your speakers.

Do not spray any kind of cleaning agent on or in close proximity to the drivers.

Could you suggest a list of suitable electronics and cables ideal for MartinLogan speakers?

We have no favorites and use electronics and cables quite interchangeably. We would suggest listening to a number of brands—and above all else—trust your ears. Dealers are always the best source for information when purchasing additional audio equipment.

Is there likely to be any interaction between my speakers and the television in my A/V system?

Yes. These speakers are not shielded and should be kept at least 2 feet away from a CRT television.

Will exposure to sunlight affect the life or performance of my speakers?

We recommend against placing any loudspeaker in direct sunlight. Ultraviolet (UV) rays from the sun can cause deterioration of cabinet, speaker cones, etc. Small exposures to UV will not cause a problem. Filtering of UV rays through glass will greatly reduce the negative effects.

Should I use a 4, 6, or 8 Ohm rated amplifier with my speakers?

All of our Motion series speakers are compatible with 4, 6 or 8 Ohm output audio amplifiers and receivers. Many of the most popular brands of AV receivers and amplifiers with 4, 6 and 8 Ohm output ratings have been thoroughly tested with all of our Motion series products and we have found no compatibility issues except under extreme listening conditions. For the best performance and sonic purity when using our Motion series products use of an amplifier or AV receiver with either a 4 or 6 Ohm output is recommended!

TROUBLESHOOTING

No Output

- Check that all system components are turned on and source material is playing.
 - Check speaker wires and connections.
 - Check all interconnecting cables.
 - If you are unable to resolve your problem, please contact your dealer or MartinLogan customer service (see below).
-

CONTACTING CUSTOMER SERVICE

Phone

(785) 749-0133

Monday – Friday

8 AM – 5 PM CT

Email

service@martinlogan.com

Social Media



GENERAL INFORMATION

WARRANTY INFORMATION

Your speakers are provided with an automatic Limited 90 Day Warranty coverage. You have the option, at no additional charge, to receive a Limited 5 Year Warranty coverage. To obtain the Limited 5 Year Warranty coverage you need to complete and return the Certificate of Registration to MartinLogan within 30 days of purchase. For your convenience MartinLogan also offers online warranty registration at www.martinlogan.com.

MartinLogan may not honor warranty service claims unless we have a completed Warranty Registration card on file! If you did not receive a Certificate of Registration with your new speakers you cannot be assured of having received new units. If this is the case, please contact your authorized MartinLogan dealer.

SERIAL NUMBER

The serial number is located on back of the speaker, directly beneath the binding posts. The serial number may also be found on the product carton.

SERVICE

Should you use your MartinLogan product in a country other than the one in which it was originally purchased, we ask that you note the following:

- 1 The appointed MartinLogan distributor for any given country is responsible for warranty servicing only on units distributed by or through it in that country in accordance with its applicable warranty.
- 2 Should a MartinLogan product require servicing in a country other than the one in which it was originally purchased, the end user may seek to have repairs performed by the nearest MartinLogan distributor, subject to that distributor's local servicing policies, but all cost of repairs (parts, labor, transportation) must be borne by the owner of the MartinLogan product.
- 3 If, after owning your speaker for six months, you relocate to a country other than the one in which you purchased your speaker, your warranty may be transferable. Contact MartinLogan for details.

SPECIFICATIONS*

Motion XT F200

Application	Floorstanding
Frequency Response	27 Hz - 25k Hz \pm 3 dB
Folded Motion Waveguide Enhanced Tweeter Dispersion (VxH)	45° x 90°
Sensitivity (2.83 volts/meter)	92 dB
Impedance Compatible with 4, 6, or 8 Ohm rated amplifier	4 ohms
Crossover Frequency	300Hz, 2600Hz (3-way)
High Frequency Driver	1.25" x 2.4" (3.2 x 6.1cm) Gen2 Obsidian Folded Motion XT Tweeter with 12.4 in2 (79.8 cm2) diaphragm
Mid Frequency Driver	6.5" (16.5cm) Nomex Reinforced Kevlar® cone with cast aluminum basket. Non-resonant sealed chamber format. Unibody cone construction.
Low Frequency Drivers	3x 8" (20.3cm) aluminum cones with cast aluminum baskets. Non-resonant asymmetrical chamber format. Unibody cone construction
Cabinet	Bottom Ported
Recommended Amp Power	20 - 600 watts
Binding Post Inputs	Custom bi-amp/bi-wire capable 5-way binding posts
Weight	86lbs / 39kg
Dimensions (HxWxD) Floorstanding model dimensions include the feet. Depth for all models include the binding posts. .	50-3/4" x 13-3/4" x 16-1/2" 14.6cm x 34.9cm x 41.9cm
Finishes	Gloss Black, Walnut, and Satin White

*Specifications are subject to change without notice.

Motion XT F100

Floorstanding

31 Hz - 25 kHz \pm 3 dB

45° x 90°

92 dB

4 ohms

280 Hz, 2600 Hz (3-way)

1.25" x 2.4" (3.2 x 6.1cm) Gen2 Obsidian
Folded Motion XT Tweeter with 12.4 in2 (79.8
cm²) diaphragm

6.5" (16.5cm) Nomex Reinforced Kevlar® cone
with cast aluminum basket. Non-resonant sealed
chamber format. Unibody cone construction.

3x 6.5" (16.5cm) aluminum cones with cast alumi-
num baskets. Non-resonant asymmetrical chamber
format. Unibody cone construction.

Bottom Ported

20 - 450 watts

Custom bi-amp/bi-wire capable 5-way binding posts

76lbs / 34.5kg

47-3/4" x 12-1/2" x 13-1/2" 121.3cm x
88.6cm x 34.3cm

Gloss Black, Walnut, and Satin White

Motion XT C100

Center Channel

42 Hz - 25 kHz \pm 3 dB

45° x 90°

93 dB

5 ohms

1,300 Hz, 2,500 Hz (2.5-way)

1.25" x 2.4" (3.2 x 6.1cm) Gen2 Obsidian
Folded Motion XT Tweeter with 12.4 in2 (79.8
cm²) diaphragm

2x 6.5" (16.5cm) Nomex Reinforced Kevlar®
cones with cast aluminum baskets. Non-resonant
asymmetrical chamber format. Unibody cone
construction. Anti-lobing 2.5-way crossover design.

—

Rear Ported

20 - 300 watts

Custom bi-amp/bi-wire capable 5-way binding posts

34lbs / 15.4kg

8" x 24" x 14-1/2" 20.3cm x 61cm x 36.8cm

Gloss Black, Walnut, and Satin White

SPECIFICATIONS*

Motion XT B100

Application	Bookshelf
Frequency Response	45 Hz - 25 kHz \pm 3 dB
Folded Motion Waveguide Enhanced Tweeter Dispersion (VxH)	45° x 90°
Sensitivity (2.83 volts/meter)	93 dB
Impedance Compatible with 4, 6, or 8 Ohm rated amplifier	4 ohms
Crossover Frequency	2,600 Hz (2-way)
High Frequency Driver	1.25" x 2.4" (3.2 x 6.1cm) Gen2 Obsidian Folded Motion XT Tweeter with 12.4 in ² (79.8 cm ²) diaphragm
Mid Frequency Driver	6.5" (16.5cm) Nomex Reinforced Kevlar® cone with cast aluminum basket. Non-resonant asymmetrical chamber format. Unibody cone construction.
Low Frequency Drivers	—
Cabinet	Rear Ported
Recommended Amp Power	20 - 250 watts
Binding Post Inputs	Custom bi-amp/bi-wire capable 5-way binding posts
Weight	20.5lbs / 9.3kg
Dimensions (HxWxD) Floorstanding model dimensions include the feet. Depth for all models include the binding posts. .	14-1/2" x 8" x 12-1/2" 36.8cm x 20.3cm x 31.8cm
Finishes	Gloss Black, Walnut, and Satin White

*Specifications are subject to change without notice.

Motion F20

Floorstanding

35 Hz - 25kHz \pm 3 dB

90° x 90°

92 dB

4 ohms

230 Hz, 2,600 Hz (3-way)

1" x 1.4" (2.6 x 3.6cm) Gen2 Obsidian Folded Motion Tweeter with 9.2 in2 (59.4 cm2) diaphragm

5.5" (14cm) Woven Fiberglass cone with cast polymer basket. Non- resonant sealed chamber format. Unibody cone construction.

2x 6.5" (16.5cm) aluminum cones with cast polymer baskets. Non-resonant asymmetrical chamber format. Unibody cone construction.

Bottom Ported

20 - 300 watts

Custom bi-amp/bi-wire capable 5-way binding posts

60lbs / 27.2kg

44-3/4" x 11-3/4" x 14-1/4"
112.7cm x 29.8cm x 36.2cm

Gloss Black, Walnut, and Satin White

Motion F10

Floorstanding

38 Hz - 25 kHz \pm 3 dB

90° x 90°

92 dB

4 ohms

280 Hz, 3,000 Hz (3-way)

1" x 1.4" (2.6 x 3.6cm) Gen2 Obsidian Folded Motion Tweeter with 9.2 in2 (59.4 cm2) diaphragm

5.5" (14cm) Woven Fiberglass cone with cast polymer basket. Non- resonant sealed chamber format. Unibody cone construction.

2x 5.5" (14cm) aluminum cones with cast polymer baskets. Non-resonant asymmetrical chamber format. Unibody cone construction.

Bottom Ported

20 - 250 watts

Custom bi-amp/bi-wire capable 5-way binding posts

50.5lbs / 22.9kg

38-1/4" x 11-1/4" x 13-1/4" 97.1cm x
28.6cm x 7.6cm

Gloss Black, Walnut, and Satin White

SPECIFICATIONS*

Motion C10

Application	Center Channel
Frequency Response	63 Hz - 25 kHz \pm 3 dB
Folded Motion Waveguide Enhanced Tweeter Dispersion (VxH)	90° x 90°
Sensitivity (2.83 volts/meter)	93 dB
Impedance Compatible with 4, 6, or 8 Ohm rated amplifier	4 ohms
Crossover Frequency	1000 Hz, 2,000 Hz (2.5-way)
High Frequency Driver	1" x 1.4" (2.6 x 3.6cm) Gen2 Obsidian Folded Motion Tweeter with 9.2 in2 (59.4 cm2) diaphragm
Mid Frequency Driver	2x 5.5" (14cm) Woven Fiberglass cones with cast polymer baskets. Non-resonant sealed chamber format. Unibody cone construction. Anti-lobing 2.5-way crossover design.
Low Frequency Drivers	—
Cabinet	Rear Ported
Recommended Amp Power	20 - 200 watts
Binding Post Inputs	Custom 5-way binding posts
Weight	23.5lbs / 10.7kg
Dimensions (HxWxD) Floorstanding model dimensions include the feet. Depth for all models include the binding posts. .	7-1/4" x 19" x 11-1/2" 18.4cm x 48.3cm x 29.3cm
Finishes	Gloss Black, Walnut, and Satin White

*Specifications are subject to change without notice.

Motion B10

Bookshelf

56 Hz - 25 kHz \pm 3 dB

90° x 90°

92 dB

5 ohms

2,370 Hz (2-way)

1" x 1.4" (2.6 x 3.6cm) Gen2 Obsidian Folded Motion Tweeter with 9.2 in2 (59.4 cm2) diaphragm

5.5" (14cm) Woven Fiberglass cone with cast polymer basket. Unibody cone construction.

-

Rear Ported

20 - 200 watts

Custom 5-way binding posts

14.5lbs / 6.6kg

12-1/2" x 7" x 9-3/4"

31.8cm x 17.8cm x 24.8cm

Gloss Black, Walnut, and Satin White

Motion MP10

Multi-Purpose

81 Hz - 25kHz \pm 3 dB

90° x 90°

9

2 dB

5 ohms

2,100 Hz (2-way)

1" x 1.4" (2.6 x 3.6cm) Gen2 Obsidian Folded Motion Tweeter with 9.2 in2 (59.4 cm2) diaphragm

5.5" (14cm) Woven Fiberglass cone with cast polymer basket. Unibody cone construction.

-

Stealth Rear Ported

20 - 200 watts

Custom 5-way binding posts

9.7lbs / 4.4kg

14" x 8" x 5"

35.6cm x 20.3cm x 12.7cm

Gloss Black, Walnut, and Satin White

F200

MOTION XT®
by MARTIN LOGAN®

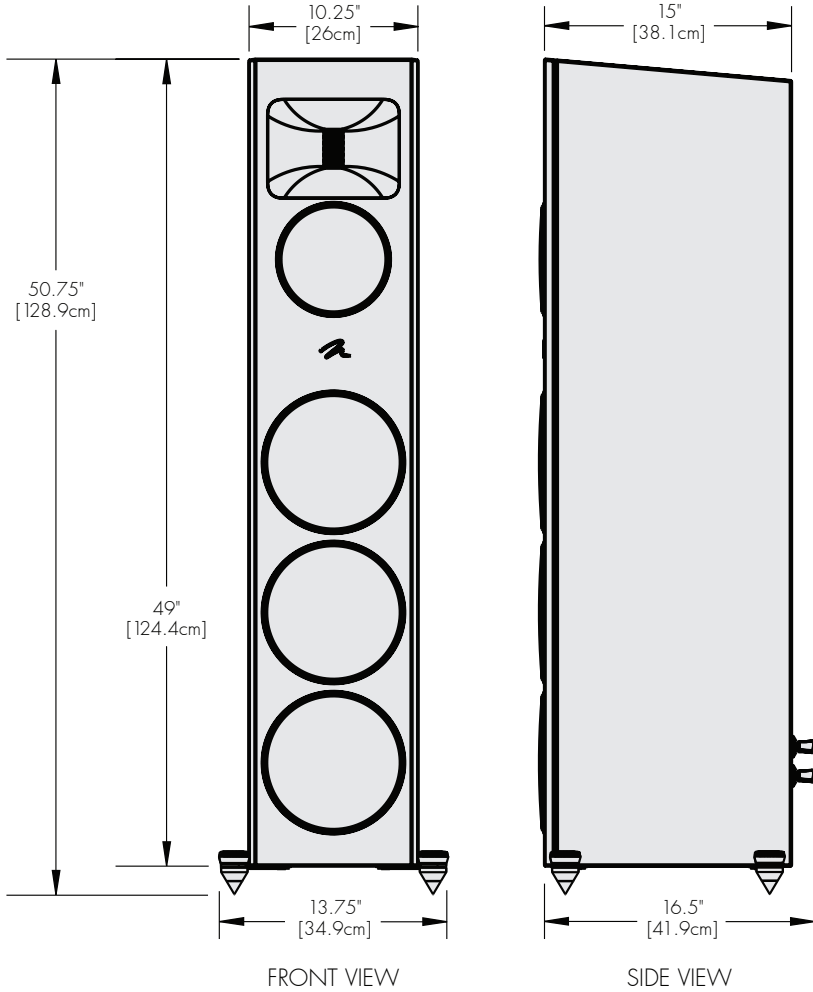

F100

MOTION XT®
by MARTIN LOGAN®

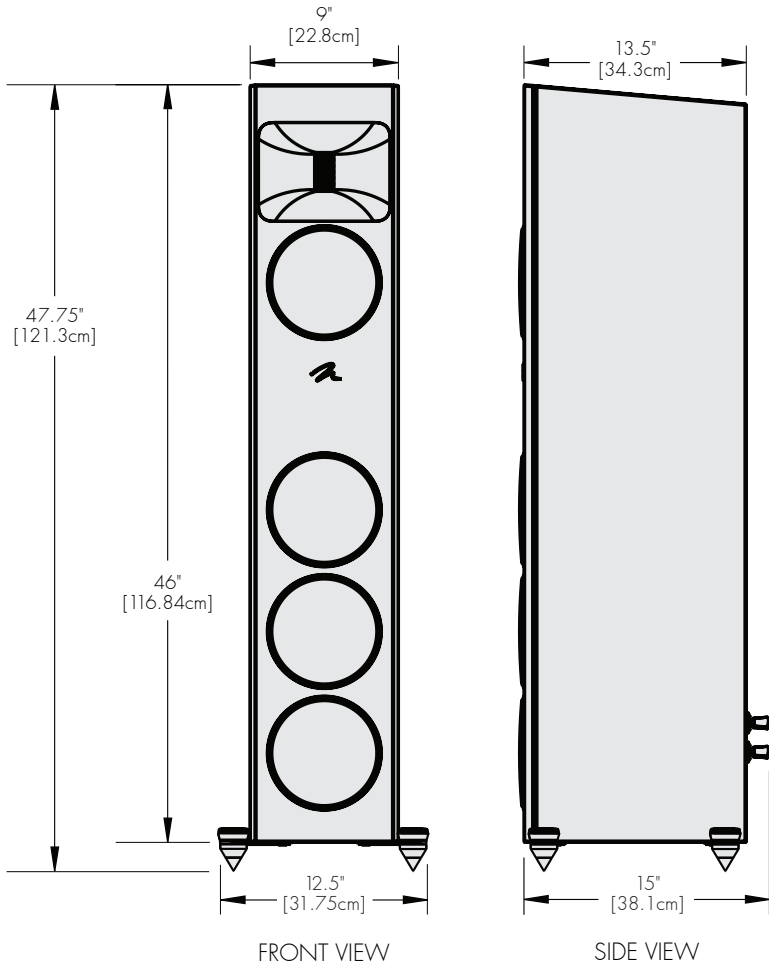

C100

MOTION XT®
by MARTIN LOGAN®

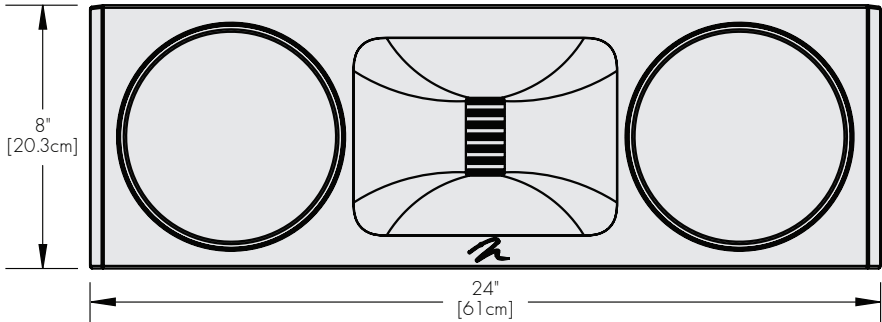

FRONT VIEW

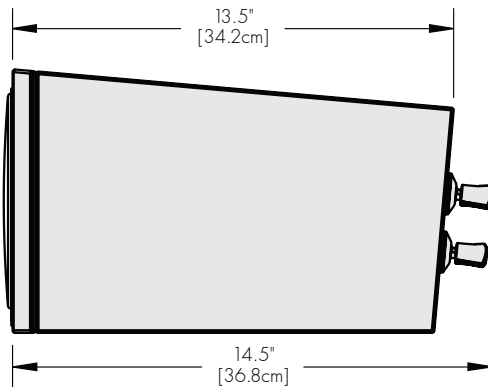

SIDE VIEW

B100

MOTION XT®
by MARTIN LOGAN®

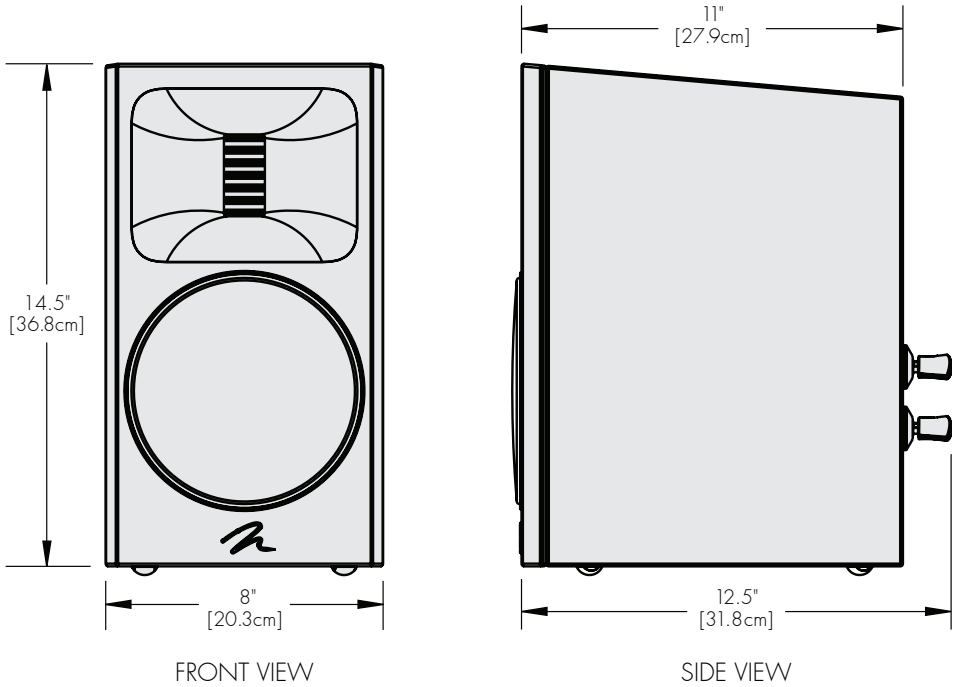

F20

MOTION®
by MARTIN LOGAN®

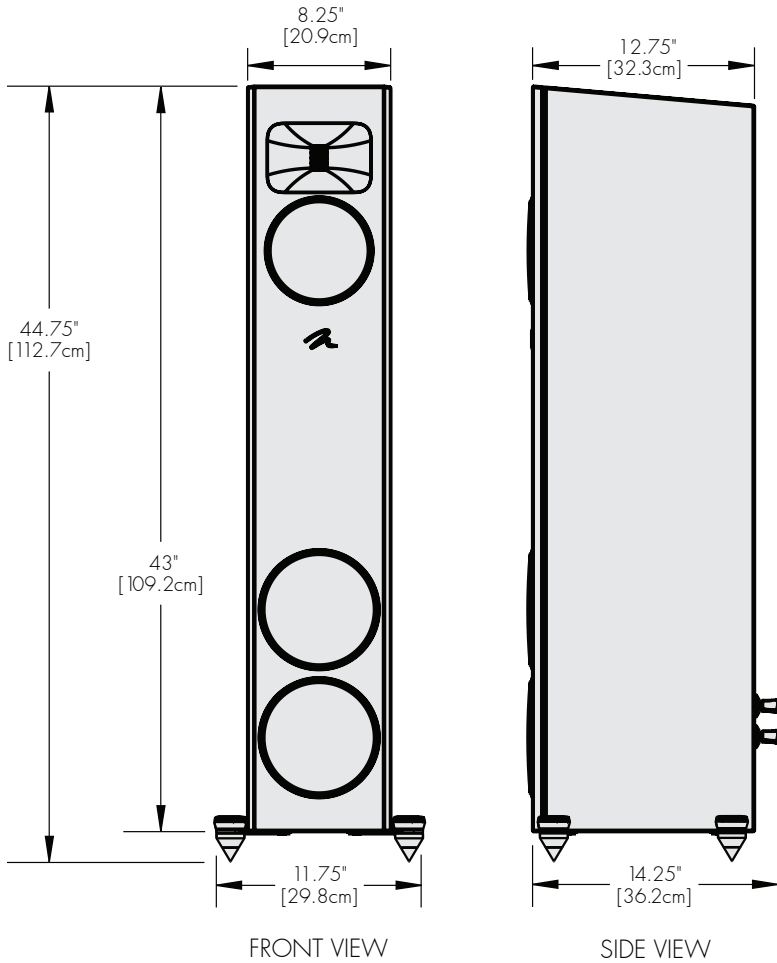

F10

MOTION®
by MARTIN LOGAN®

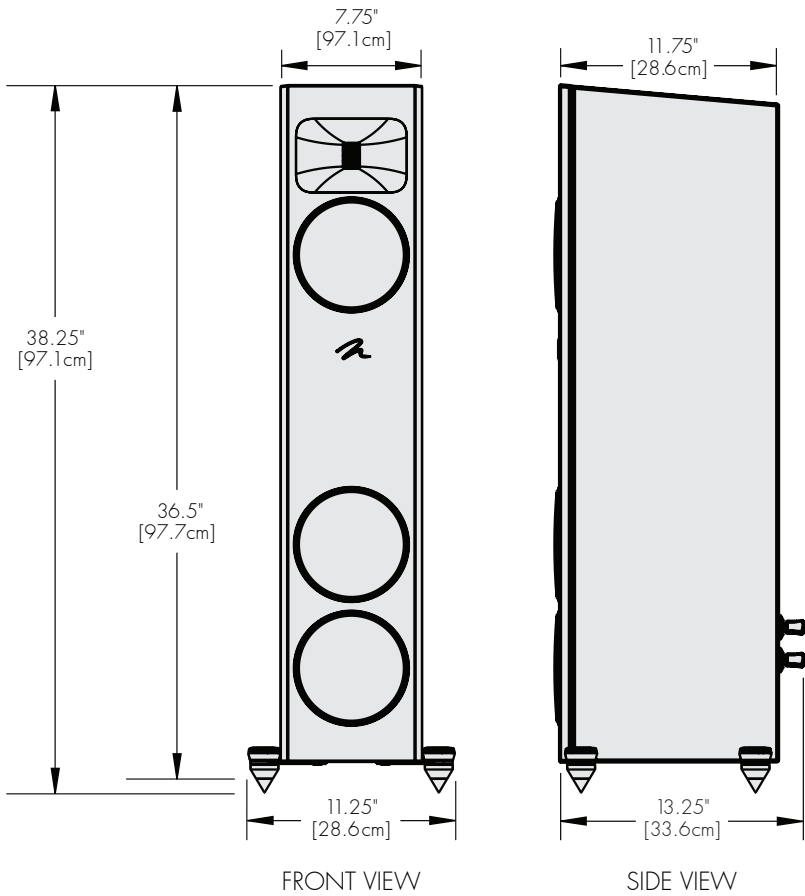

C10

MOTION®
by MARTIN LOGAN®

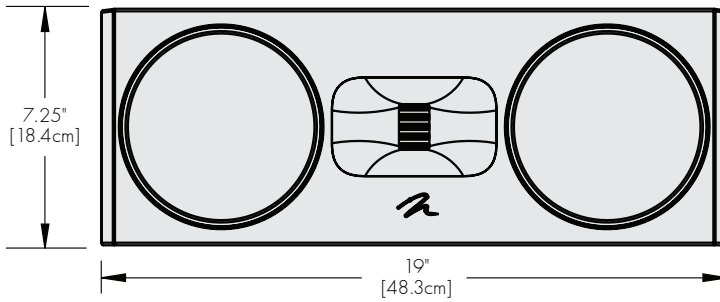

FRONT VIEW

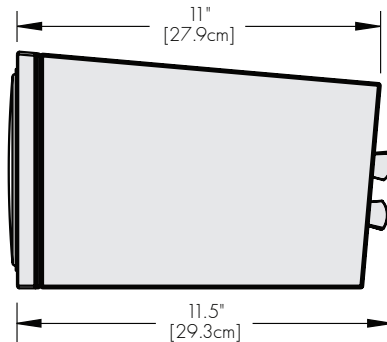

SIDE VIEW

B10

MOTION®
by MARTIN LOGAN®

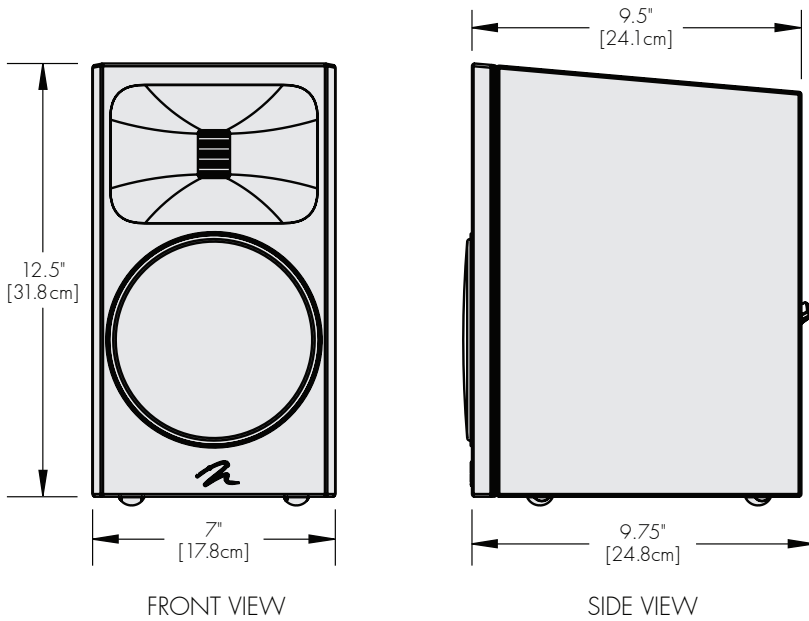

MP10

MOTION®
by MARTIN LOGAN®

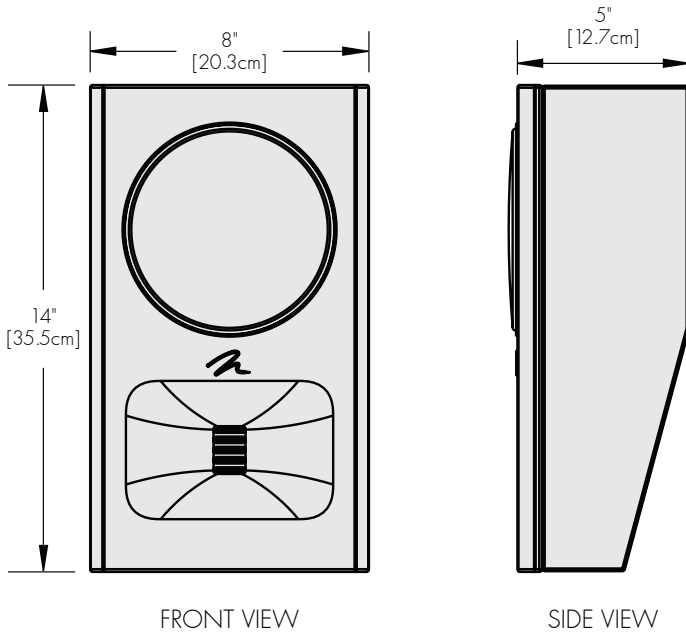



MARTIN LOGAN®

Lawrence, Kansas, USA tel. 785.749.0133 fax 785.749.5320 www.martinlogan.com

©2023 MartinLogan Ltd. All rights reserved.

Rev. #000